

Operating Instruction

Synchronizing of Track Supplies

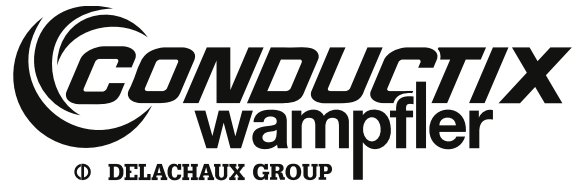

Part-No. 5-channel master module:
0172004

Part-No. 10-channel master module:
3017343

Part-No. slave module:
0172016



Synchronizing of Track Supplies

Contents

	Page
1 Symbols and Hints	3
2 Advisory Information for the User	4
3 Technical Description	5
4 Transport and Storage	7
5 Place and conditions of installation	7
6 Site preparation	7
7 Installation master module	8
7.1 Who is authorized to carry out the installation	8
7.2 Installation Procedure	8
8 Installation slave module	10
8.1 Who is authorized to carry out the installation	10
8.2 Slave module Version 2	10
9 Commissioning of the synchronizing system	11
9.1 Who is allowed to carry out commissioning	11
9.2 Configuration of power and control plugs	11
10 Fault diagnosis	12
11 Maintenance and repair	12
12 Actions in case of emergency	12
13 Disassembly / reuse	13
13.1 Safety advice for disassembly and disposal	13
13.2 Recycling	13
14 Dimensions master modules	14
14.1 5-channel master module	14
14.2 10-channel master module	15

We reserve the right to carry out technical modifications of illustrations and statements in these operating manual, in order to improve the energy supply system and its functions.

Reprint and duplication, even of abstracts, is only permitted with our approval in written form.

© Conductix-Wampfler GmbH 2003

1 Symbols and Hints



Warning of Voltage

This symbol can be found in several places in the operating instructions where special care has to be taken due to a voltage presence which is hazardous to people. Please observe these instructions and be careful in those cases. Please apply all health and safety regulations to other users as well. Always disconnect the system from the main supply prior to carrying out any work on the energy supply system.



Attention – some Hints

This sign draws the attention to parts of the operating instructions where the regulations, advice and correct operational sequence must be observed to avoid any damage or destruction to the energy supply system and its components.



Temperature

This sign draws the attention to parts of the operating instructions, where special care must be taken because of hot surfaces or where inductive heating of ferromagnetic material may occur and where special measures have to be taken. Please pass on the advice to other users as well.

Synchronizing of Track Supplies

2 Advisory Information for the User



When the track supplies are open they can contain live voltage and hot surfaces!



Unauthorized removal of covers, improper operation, faulty installation or faulty operation involve risk of severe injuries to persons and damage to components.



All installation and commissioning works as well as repair works and disassembly have to be carried out by qualified staff (IEC 364 respectively CENELEC HD 384 or DIN VDE 0100 and IEC 664 or DIN VDE 0110 and national safety rules).

Qualified staff according to the safety regulations are persons that are familiar with the installation, assembly, commissioning and operation of the energy supply system and that have the appropriate qualifications.

Conductix-Wampfler GmbH cannot be responsible for damage or breakdowns that have been caused by not observing the operating instructions.

This instruction exclusively contains details of the synchronizing system. Many notable points occur only for components of the power supply system. These points are exclusively explained in the documentation of those components. Please refer to these documents for further information. Please observe the operating instructions of the track supply before attempting to use the synchronization system.

Synchronizing of Track Supplies

3 Technical Description

Depending on the installation it may be necessary to use a system consisting of several track supplies. E.g. maintenance tracks that can be turned on and off independently of the whole system or in large installations with long segments of tracks or with different emergency-stop-zones.

When two tracks are utilized to make a single system, they must physically meet at some point. At this point the magnetic fields of both cables are combined to a single field. When the two fields have about the same phase there will be no remarkable weakening of the field and thereby no reduction of the transmitted power. If the fields are 180 degree's out of phase then they will cancel each other out, thus leaving that small area of track with no power. This problem can be avoided through synchronizing of the track supplies and thereby of the magnetic fields.

Each system consists of a stand alone central master module and up to ten slave modules (up to 5 slave modules in case of a 5-channel master module 0172004; up to 10 slave modules in case of a 10-channel master module 3017343) which are installed in a track supply (on the control board) for each track to be synchronized. The master module sends out a synchronizing signal to the slaves. When the track supply drifts in frequency and phase, the slave module tries to shift it back to correspond to the master signal. The slave module will generate its own signal if the master does not provide one. This insures the system continues to function when the master is disconnected or fails. When the slave module generates its own signal there will be no synchronizing to other slave modules. This may result in a reduced power transmission at transfer points. In this case please refer to the chapter „Fault diagnosis“.

Synchronizing of Track Supplies

Setup shown: 5 channel master synchronizing 5 slave modules

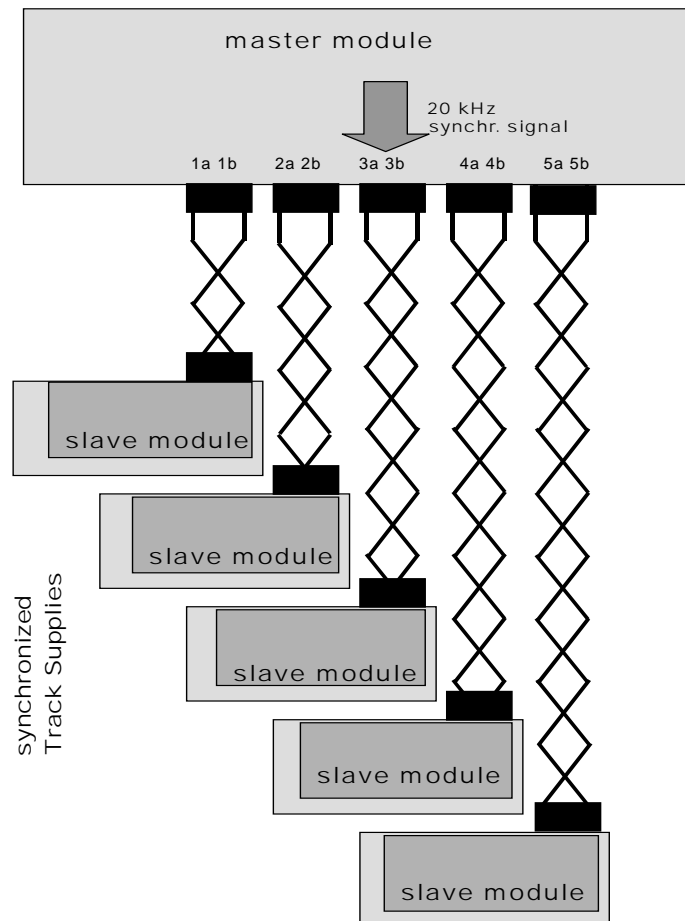

Synchronizing of Track Supplies

4 Transport and Storage

The transport company must be advised about any damage that has been detected after delivery. Prior to installing or starting operation of damaged components please consult the supplier.

5 Place and conditions of installation



Always install the synchronizing master in a dry and ventilated control cabinet. Ideally near to the central control, which controls the synchronized track supplies. The slave modules have to be installed in a track supply. The physical distance between the control cabinet and the track supply shall be not longer than 200 m*.

Climatic conditions for storage and operation according to the specifications of the track supplies have to be observed. The master modules have to be treated as analog devices.

6 Site preparation



There must be a 24 V DC / 500 mA supply available in the control cabinet for use by the master module (the same power supply is used for the 2 power inputs of the 10-channel master module). The supply of the slave module is provided by the control board of the track supply.

For the synchronizing two free cores in the control cables are needed. These create the connection between the central module and the track supplies. If there are not enough free cores available, the cables have to be replaced by cables with enough free cores.

*Based on a connection via „Ölflex Classic 100 2x1,5 mm“ cable. Other cable may bring different results!

Synchronizing of Track Supplies

7 Installation master module

7.1 Who is authorized to carry out the installation



All installation and commissioning works as well as maintenance works and disassembly have to be carried out by qualified staff (IEC 364 respectively CENELEC HD 384 or DIN VDE 0100 and IEC 664 or DIN VDE 0110 and national safety rules).

Qualified staff according to the safety regulations are persons that are familiar with the assembly and installation of the energy supply system and that have the appropriate qualifications.

7.2 Installation Procedure

The installation can be done while the tracks are still live.

1. Locate the central control cabinet.
2. Mount the Din rail clips to the master in the required orientation.
3. Remove the 2 pin power plug from the socket.
4. Wire the 24 V DC supply to the plug. (DON'T PLUG IT IN)
5. Remove the 10 pin output plug from the socket.
6. Wire up the output channels. Pin **a** of each channel should go to core 9, pin **b** of each channel should go to core 10 (see illustration for details).
7. Leave the output plug unplugged and proceed to installing the slave units.

Synchronizing of Track Supplies

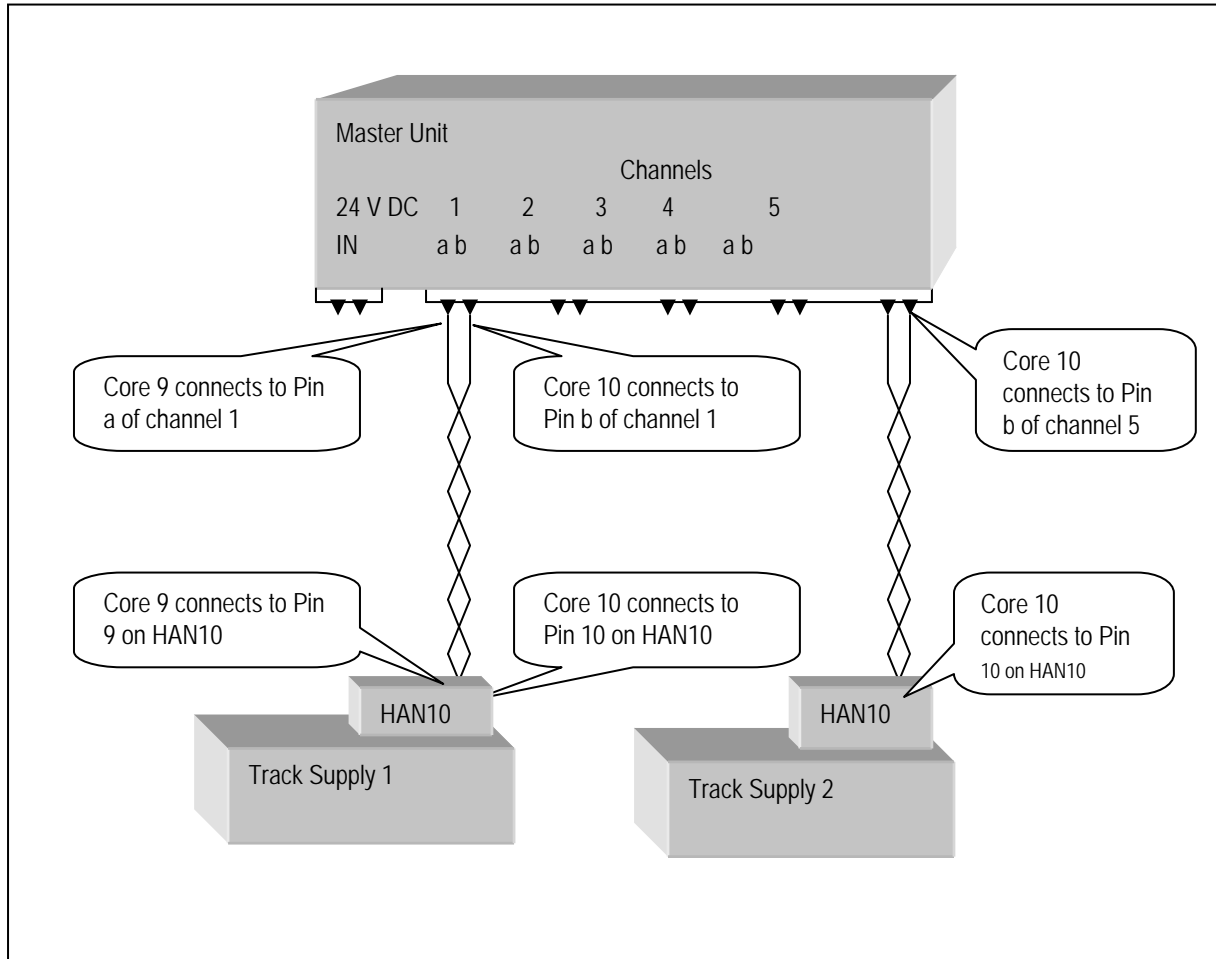

Synchronizing of Track Supplies

8 Installation slave module

8.1 Who is authorized to carry out the installation



All installation and commissioning works as well as maintenance works and disassembly have to be carried out by qualified staff (IEC 364 respectively CENELEC HD 384 or DIN VDE 0100 and IEC 664 or DIN VDE 0110 and national safety rules).

Qualified staff according to the safety regulations are persons that are familiar with the assembly and installation of the energy supply system and that have the appropriate qualifications.

8.2 Slave module Version 2

Slave module Version 2 (only use with control board 91-P600-0049b):

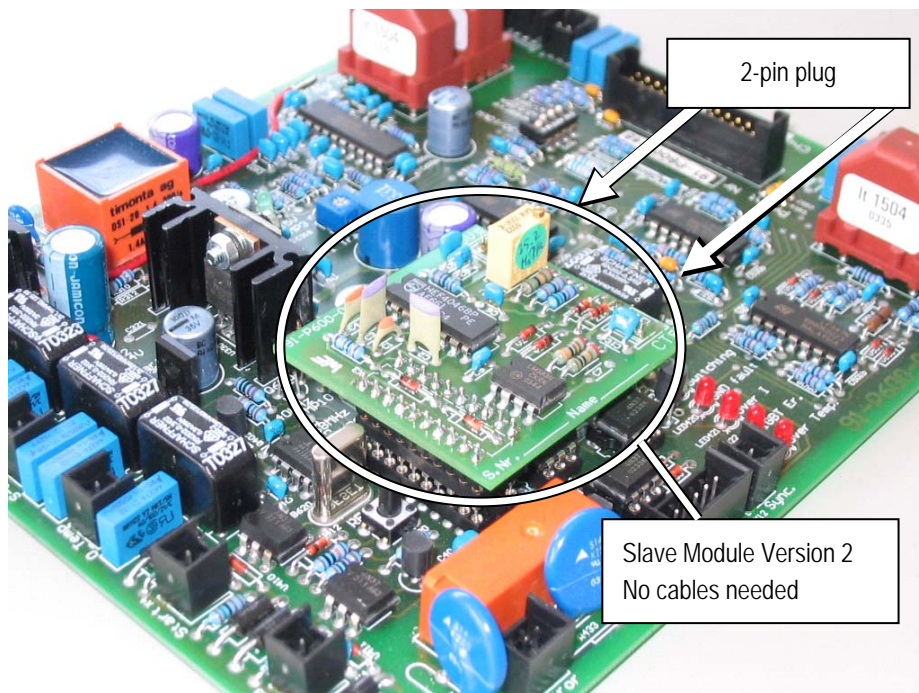

Synchronizing of Track Supplies

9 Commissioning of the synchronizing system

To commission the system each track supply must be individually tuned. This ensures that the complete system is synchronizing to a single reference.

9.1 Who is allowed to carry out commissioning



All installation and commissioning works as well as maintenance works and disassembly have to be carried out by qualified staff (IEC 364 respectively CENELEC HD 384 or DIN VDE 0100 and IEC 664 or DIN VDE 0110 and national safety rules).

Qualified staff according to the safety regulations are persons that are familiar with the assembly and installation of the energy supply system and that have the appropriate qualifications. Commissioning should be done by Conductix-Wampfler approved / trained personnel.

9.2 Configuration of power and control plugs

Observe the details of the operating instructions of the track supplies.

Synchronizing of Track Supplies

10 Fault diagnosis

If there appears a decrease of transferred power especially in overlapping zones between separately supplied primary tracks, then the synchronizing needs to be checked.

At first the function of the master module has to be checked. When the LED's are off, but the voltage supply is confirmed correct, the master module must be exchanged by a qualified person, as described in chapter 7.1. A complete commissioning is not necessary, unless the cable configuration is changed.

If the master module is functioning, then it should be checked where along the track the loss of power is occurring, and the connections to the slave module in the Track Supply on that zone verified. If they are correct, then the slave module should be replaced. This must be done by a qualified person as described in chapter 8.1. A complete commissioning is not necessary, unless the cable configuration is changed.

If the problem cannot be eliminated using these procedures then a complete re-commissioning, as described above, has to be done. A detailed check and if necessary a repair of the components is only possible in the Conductix-Wampfler factory.

Any intervention in the power transfer system and/or synchronizing system, which results in a change of cables and/or configuration of the cables, makes a re-commissioning of the system necessary, otherwise a loss of power cannot be excluded.

11 Maintenance and repair

A separate maintenance of the master and slave modules is not necessary. The maintenance for the modules is carried out with the maintenance for the track supplies.

12 Actions in case of emergency

In case of an abnormal state of operation – for example if there is smoke in the unit – disconnect the feeding converter immediately from the voltage supply!

Unauthorized switching on by a third person has to be prevented by removing the line fuses of the main supply or by adequate measures on site.

After switching off the supply voltage wait at least 5 minutes on account of charged capacitors before starting the disassembly of the energy supply system.

The dangerous zone has to be provided with warning signs and secured with a shut-off tape against entry by unauthorized persons.

Synchronizing of Track Supplies

13 Disassembly / reuse

If it is necessary to exchange the track supply, master or slave modules due to damage or to install it in another place, verify that no damage will occur during dismounting.

Please observe that all components of an energy supply system affect the system tuning. For installation in another place observe the described mounting and commissioning instructions. Improper application, wrong installation or operation involve the danger of severe injuries to persons and damage to objects.



All disassembly works have to be carried out by qualified staff (IEC 364 respectively. CENELEC HD 384 or DIN VDE 0100 and IEC 664 or DIN VDE 0110 and national safety rules).

Qualified staff according to the safety regulations are persons that are familiar with the installation, assembly, commissioning and operation of the energy supply system and that have the appropriate qualifications.

13.1 Safety advice for disassembly and disposal

Follow the instructions of the operation instruction of the track supply.

13.2 Recycling

The master and slave modules contain components that have to be disposed of in a specific way. If they are not used any longer, they will have to be recycled.

Hint:

Unused slave modules should be safely stored in a clean and dry environment in case of future use.

Synchronizing of Track Supplies

14 Dimensions master modules

14.1 5-channel master module

(Part-Number: 0172004)

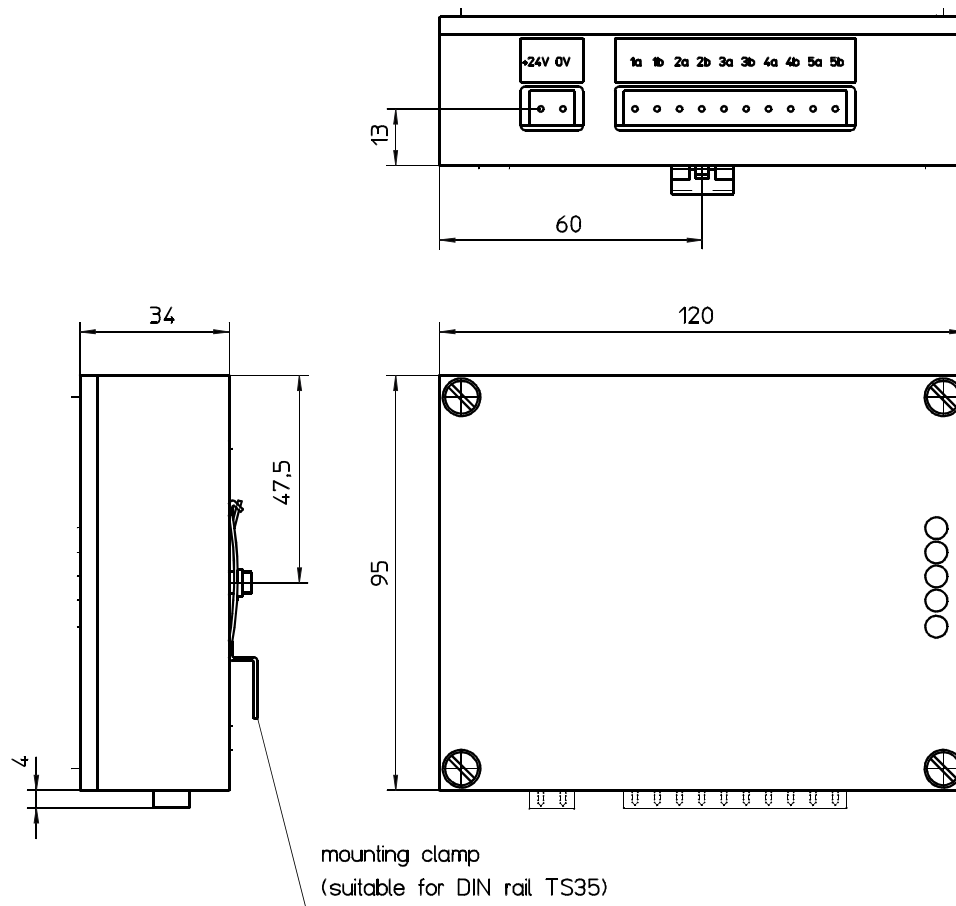

Synchronizing of Track Supplies

14.2 10-channel master module

(Part-Number: 3017343)

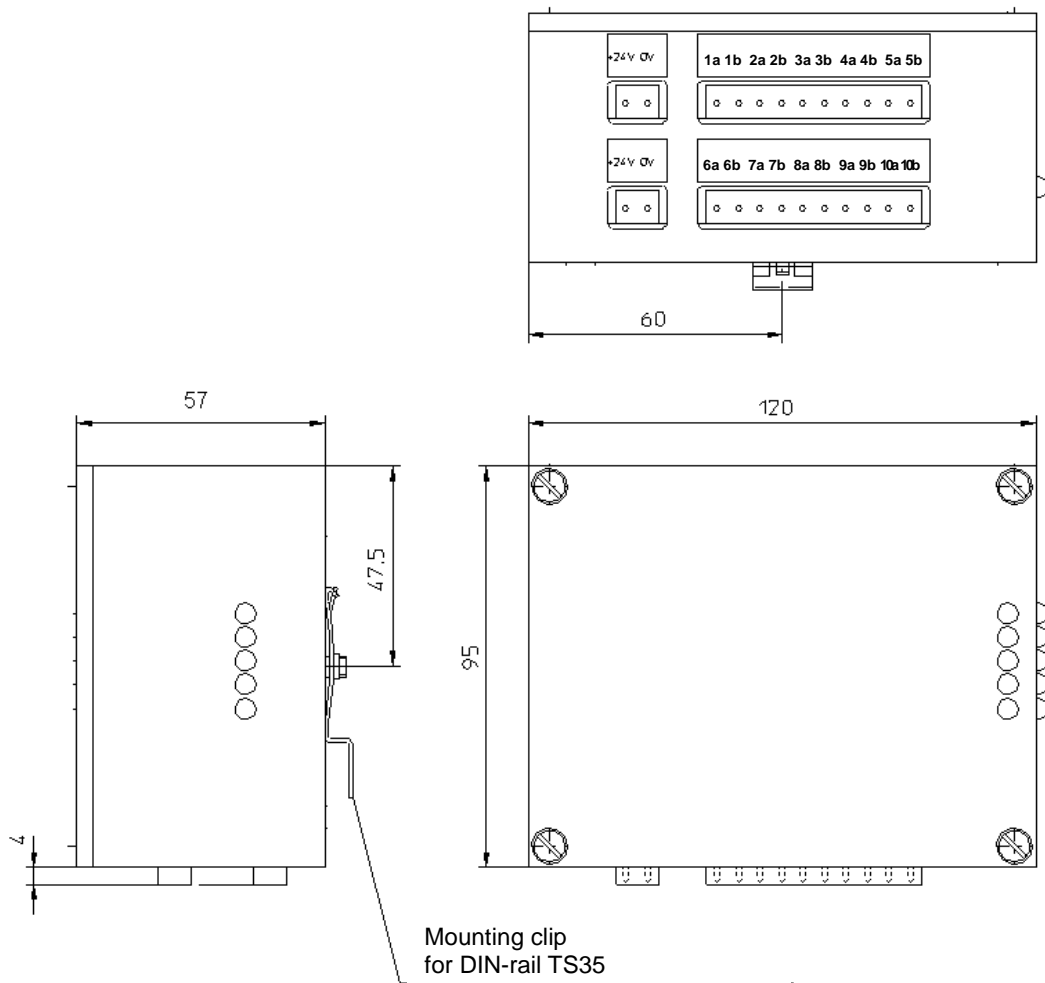

Operating Instruction

Synchronizing of
Track Supplies

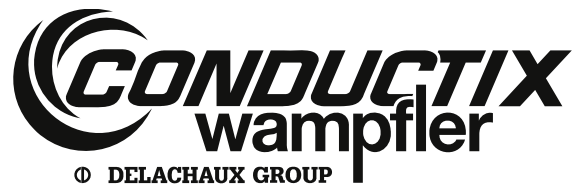

Conductix-Wampfler GmbH
Rheinstrasse 27 + 33
79576 Weil am Rhein - Maerk
Germany

Phone: +49 (0) 7621 662-0
Fax: +49 (0) 7621 662-144
info.de@conductix.com
www.conductix.com